



DATA SHEET

Model No. : ANT07-1000PC
Description : 760~862 MHz PANEL ANTENNA
Date : 2010/06/07
Rev : 1

1/8

Fly to Anywhere™

WNet
Green Network™



1. OVERVIEW & SPECIFICATIONS

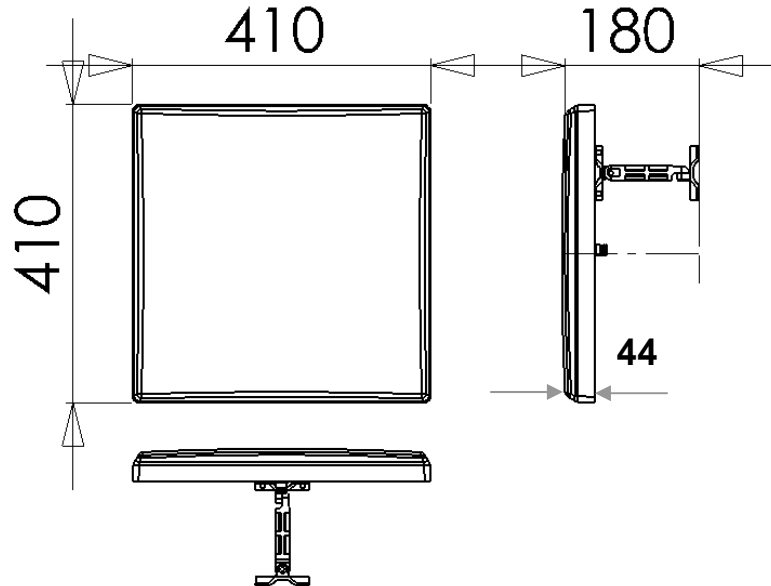

Electrical Specifications:

Frequency Range :	760~862 MHz
VSWR :	≤ 2.0
Impedance :	50Ω ± 5Ω
Gain :	10 dBi
Polarization :	Vertical
Power Handling :	10 Watt

Mechanical Specifications:

Connector :	N Female
Operation Temp. :	-30°C ~ +60°C
Material :	Radome: ABS Mount: Zinc Alloy
Dimension (L*W*H) :	410*410*44 mm
Weight :	1820g ± 20g
Color :	COOL GRAY 5C



3D Illustration





2. TESTING CONDITION

2.1 TEST SETUP

VSWR measurement (S11): Use ROHDE & SCHWARZ ZV8 Network Analyzer with Harbour RG-142 coaxial cable: 1000mm length in free space.

2.1.1 VSWR

The table as below summarizes concern about Return loss measurement according to The frequency band is based on FWS design. The detail be shown as appendix that is from ROHDE & SCHWARZ ZV8 Network Analyzer

VSWR Performance			
Freq(MHz)	760	800	862
Free space	1.89	1.5	2



3. GAIN MEASUREMENT

3.1 TEST SETUP

The gain of the antenna was measured by **FWS** Chamber. The chamber provides less than -30 dB reflectivity from 800 MHz through 6 GHz and a 60cm diameter spherical quiet zone. The measurement results are calibrated using both **SCHWARZBECK** horn standards. A decoupling sleeve is used to reduce feed line radiation

3.2 TEST RESULT

The peak gain is picked up as table list from Network analyzer in Chamber room, the completely gain plots also be shown as appendix.

Peak Gain (dBi)			
Freq(MHz)	760	810	862
H PLANE	9.96	9.89	8.89
E PLANE	9.88	9.47	8.97



4. APPENDIX

4.1 RETURN LOSS & VSWR

RETURN LOSS

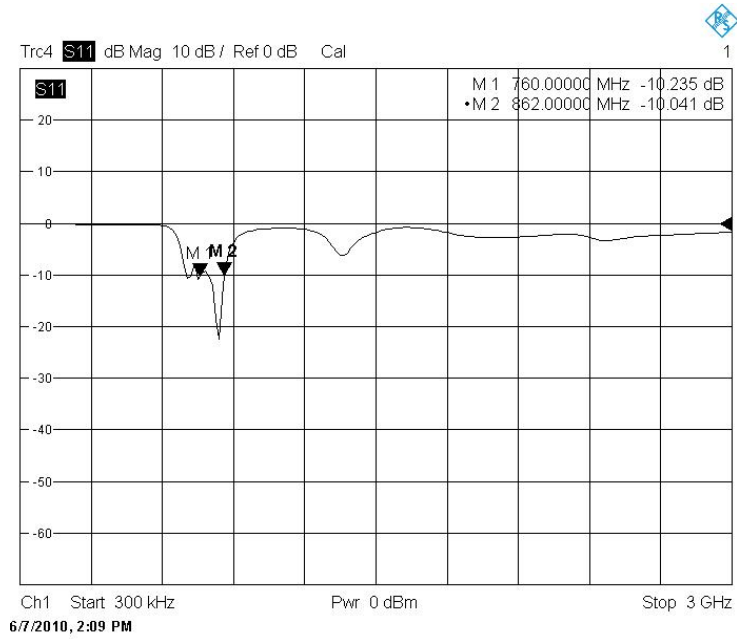

SWR

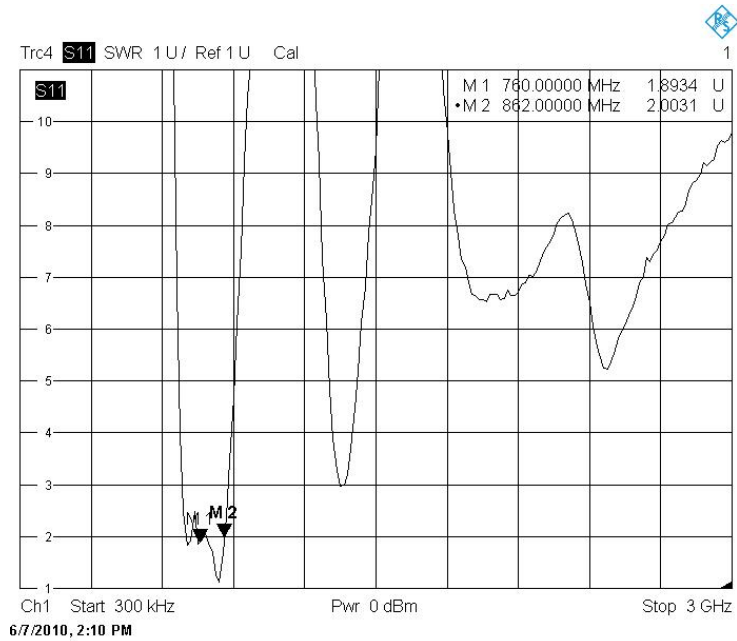

6/8

Fly to Anywhere™





4.2 RADIATION PATTERN

H-PLANE

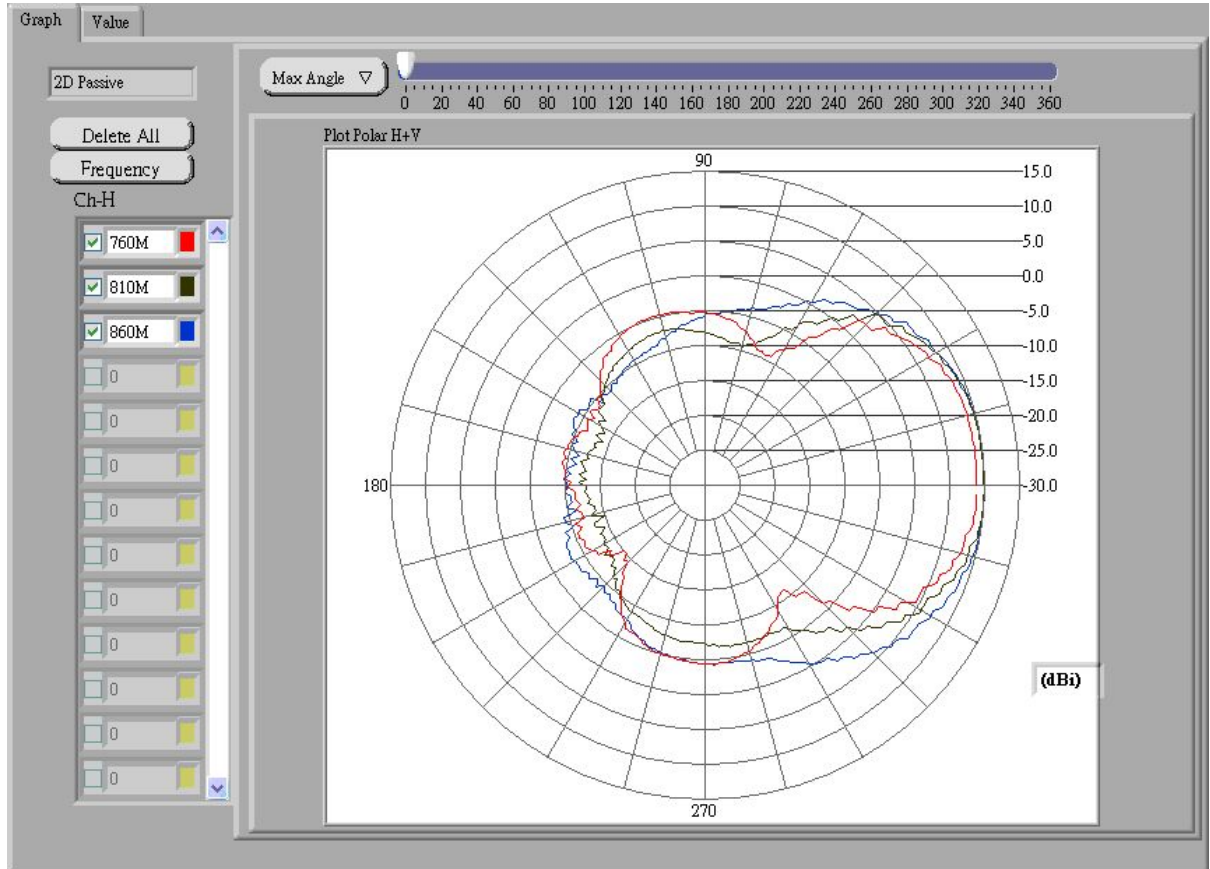



E-PLANE

